

Quick Start Manual



Symbol Explanation



This symbol denotes especially important guidelines concerning the installation and operation of the device. Not complying with the guidelines denoted by this symbol may cause an accident, damage or equipment destruction.

Basic Requirements | User Safety



- Do not use the unit in areas threatened with excessive shocks, vibrations, dust, humidity, corrosive gasses and oils.
- Do not use the unit in areas where there is risk of explosions.
- Do not use the unit in areas with significant temperature variations, exposure to condensation or ice.
- The manufacturer is not responsible for any damages caused by inappropriate installation, not maintaining the proper environmental conditions and using the unit contrary to its assignment.
- If in the case of a unit malfunction there is a risk of a serious threat to the safety of people or property additional, independent systems and solutions to prevent such a threat must be used.
- The unit uses dangerous voltage that can cause a lethal accident. The unit must be switched off and disconnected from the power supply prior to starting installation of troubleshooting (in the case of malfunction).
- Do not attempt to disassemble, repair or modify the unit yourself. The unit has no user serviceable parts.
- Defective units must be disconnected and submitted for repairs at an authorized service center.

Specifications

General	
Display	LED 6 Digit 13mm High Red Adjustable Brightness
Displayed Values	0 ~ 999999
RS485 Transmission	1200...115200 bit/s, 8N1 / 8N2
Housing Material	Polycarbonate
Protection Class	NEMA 4X IP67
Input Signal Supply	
Standard	Current: 4-20mA 0-20mA 0-5V* 0-10V*
Voltage	85 - 260V AC/DC 16 - 35V AC, 19 - 50V DC*
Output Signal Supply	
Standard	2 x Relays (5A) 1 x Relay (5A) + 4-20mA
Communication	RS485
Voltage	24VDC
Passive current output *	4-20mA (Operating Range Max. 2.8 - 24mA)
Performance	
Accuracy	0.1% @ 25°C One Digit
Temperatures	
Operating Temperature	-40 - 158°F -40 - 70°C

*Optional

Front Panel Description



Function of Push Buttons



Symbol used in the manual : [ESC/MENU]

Functions:

- Enter to main menu (press and hold for at least 3 sec.)
- Exit the current Screen and Enter to previous menu (or measure mode)
- Cancel the changes made in parameter being edited



Symbol used in the manual : [ENTER/PAUSE]

Functions:

- Start to edit the parameter
- Enter into the sub-menu
- Confirmation of changes made in parameter being edited
- While batcher mode : Pause / Start Batching



Symbol used in the manual : [Σ/RESET]

Functions:

- Switching of the display between total and instantaneous measurements or batcher counter (while batcher mode only)
- Zeroing the currently displayed counter (Press & Hold for at least 2 Sec), the zeroing must be confirmed by [ENTER] button



Symbol used in the manual : [^] [v]

Functions:

- Change of the present menu
- Modification of the parameter value
- Switching of the display between relay thresholds and number of batches counter.

Dimensions

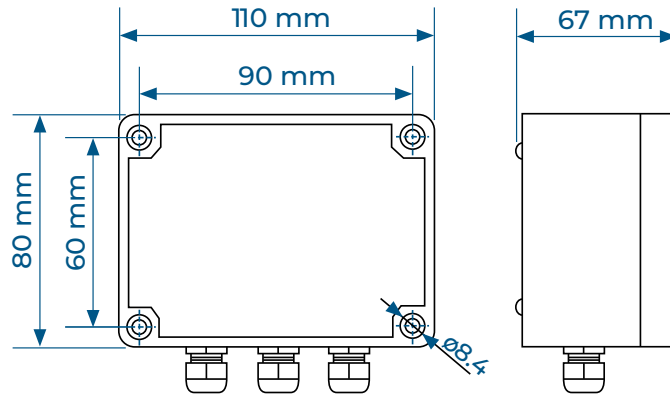

Wiring Diagram

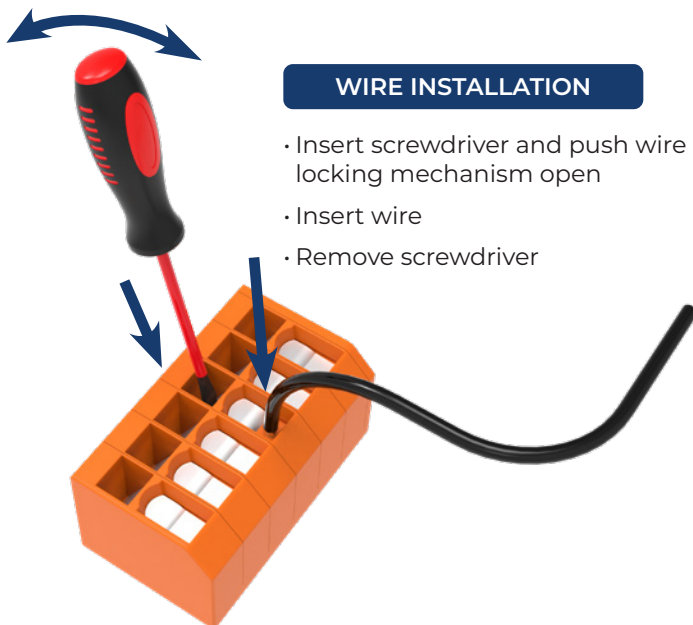
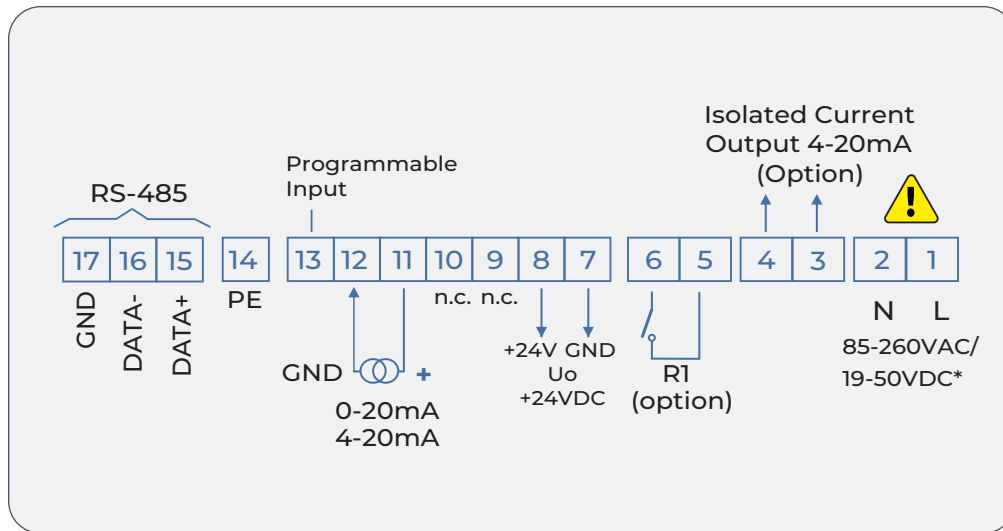

WIRE INSTALLATION

- Insert screwdriver and push wire locking mechanism open
- Insert wire
- Remove screwdriver



Due to possible significant interference in industrial installations, appropriate measures assuring correct operation of the unit must be applied.

The unit is not equipped with an internal fuse or power supply circuit breaker.

For this reason, an external time-delay cut-out fuse with a small nominal current value must be used (recommended bipolar, max. 2A) and a power supply circuit breaker located near the unit.

Power Supply & Relay Connection

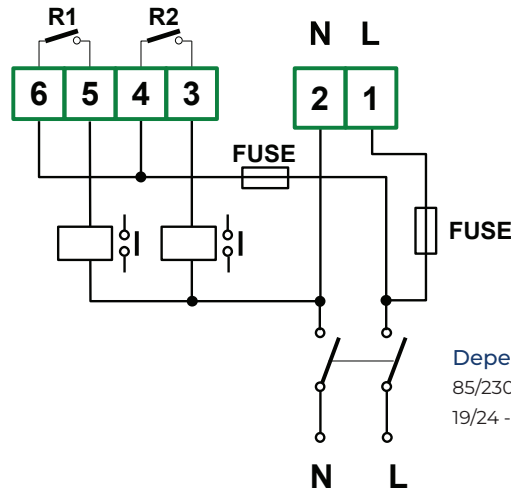

Depending on Version
85/230/260V AC/DC ; 50 - 60 Hz
19/24 - 50V DC ; 16/24/35V AC



Contacts of relay outputs are not equipped with spark suppressors. When using the relay outputs for switching of inductive loads (coils, contactors, power relays, electromagnets, motors etc.) it is required to use additional suppression circuit (typically capacitor 47nF/ min. 250VAC in series with 100R/5W resistor), connected in parallel to relay terminals or (better) directly on the load.

Suppression Circuit Connection

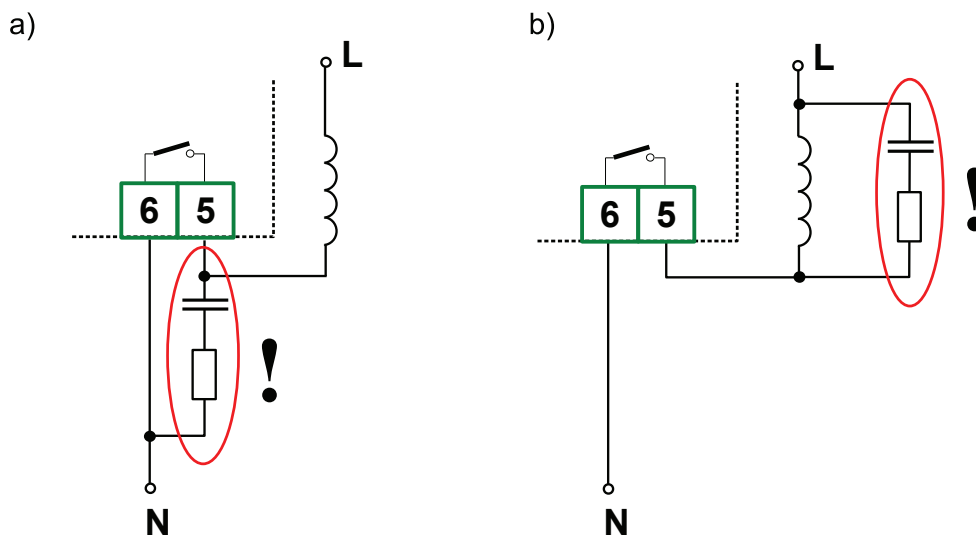

Figure: Examples of Suppression Circuit Connection
a) To Stepper Relay Terminals b) To the Inductive Load (Motor)

OC-Type Output Connection

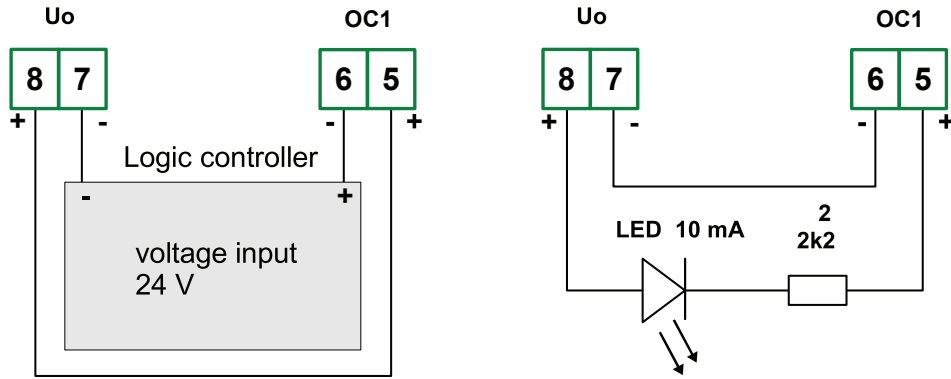

Figure: Examples of OC-type output connection

Current Output Connection Using Internal Power Supply

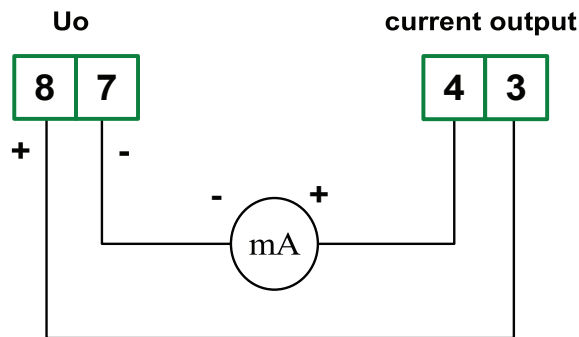

Figure: Example of current output connection using internal power supply

Current Output Connection Using External Power Supply

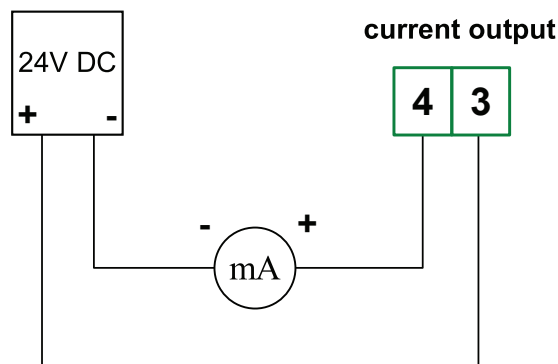
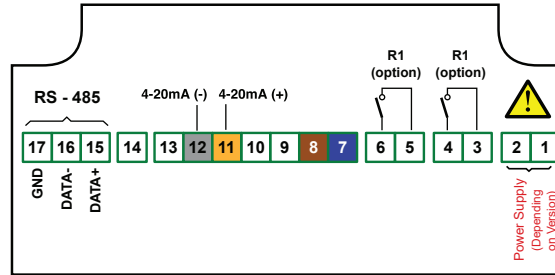

Figure: Example of current output connection using external power supply

Flow Meter Connections (Relay Type)

TKM Series : 4-20mA Output

TVF Terminal	Wire Color	Description
7	Blue	-VDC
8	Brown	+VDC
11	Yellow	mA+
12	Grey	mA-



TKS Series : Pulse Output

GPM/Pulse = K factor

TVF Terminal	Wire Color	Description
7	Blue	-VDC
8	Brown	+VDC
10	Black	NPN Pulse
Jump 13 & 8		

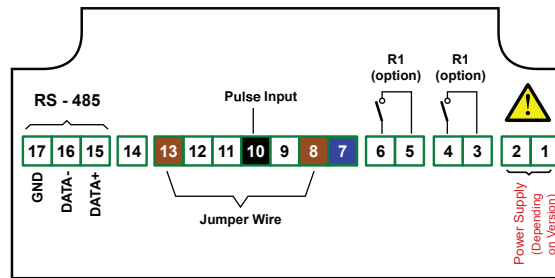

TKW Series : Pulse Output

GPM/Pulse = K factor

TVF Terminal	Wire Color	Description
7	Blue	-VDC
8	Brown	+VDC
10	Black	Pulse
Jump 13 & 8		

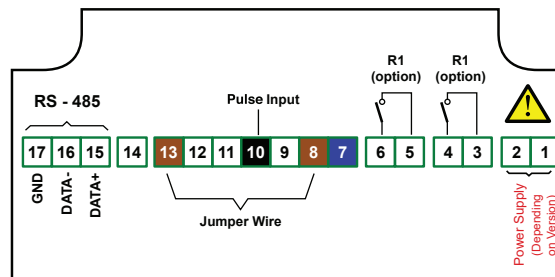

TKW Series : 4-20mA Output

TVF Terminal	Wire Color	Description
7	Blue	-VDC
8	Brown	+VDC
11	Black	mA+
12	White	mA-

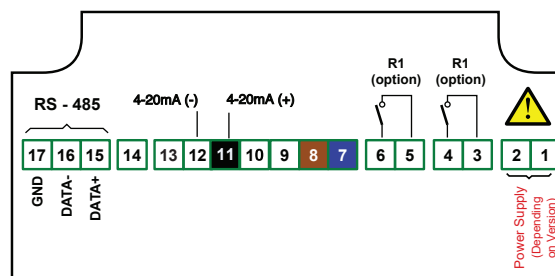

LevelPro® — TVF Series

Flow Display | Controller | Batcher

TKM TKP Series : Pulse Output		
GPM/Pulse = K factor		
TVF Terminal	Wire Color	Description
7	Blue	-VDC
8	Brown	+VDC
10	Black	Pulse
Jump 13 & 8		

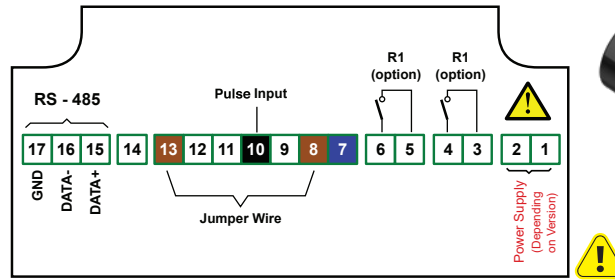

TIW Series : Pulse Output		
GPM/Pulse = K factor		
TVF Terminal	Wire Color	Description
7	Blue	-VDC
8	Brown	+VDC
10	White	Pulse
Jump 13 & 8		

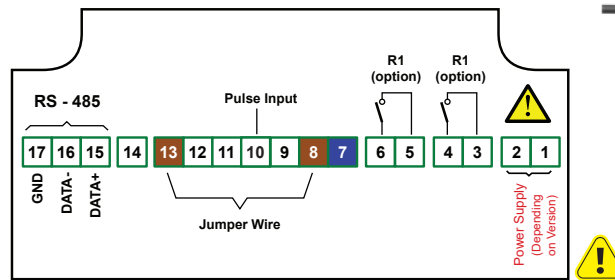

TIM TIP Series : Pulse Output		
GPM/Pulse = K factor		
TVF Terminal	Wire Color	Description
7	Blue	-VDC
8	Brown	+VDC
10	White	Pulse
Jump 13 & 8		

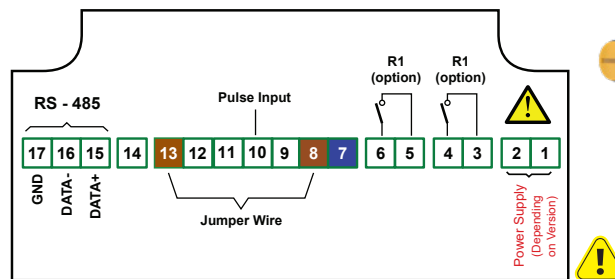

TIM Series : 4-20mA Output		
TVF Terminal	Wire Color	Description
7	Blue	-VDC
8	Brown	+VDC
11	Yellow	mA+
12	Grey	mA-

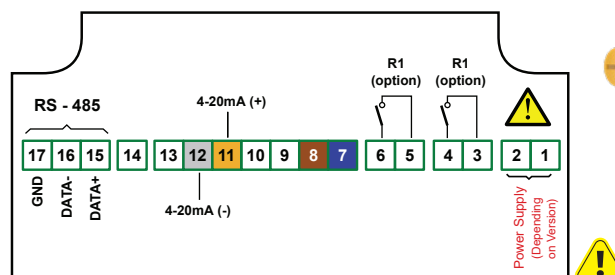

LevelPro® — TVF Series

Flow Display | Controller | Batcher

UF 1000 4000 5000 – Pulse Output		
GPM/Pulse = K factor		
TVF Terminal	Pin	Description
8	1	+VDC
10	2	Pulse
7	3	-VDC
Jump 13 & 8		

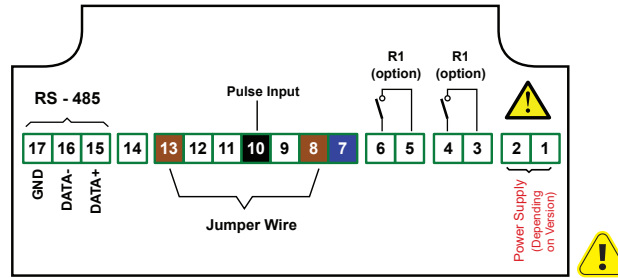

UF 1000 4000 5000 – 4-20mA Output		
TVF Terminal	Pin	Description
8	1	+VDC
11	2	+mA
7	3	-VDC
Jump 12 & 7		

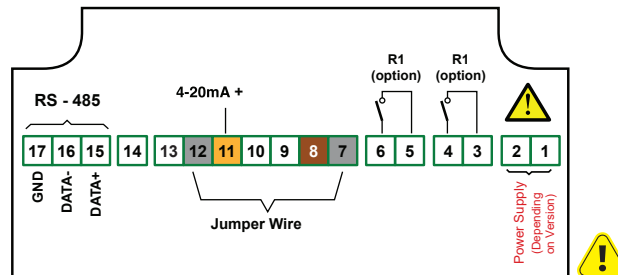

ProPulse (Flying Lead) – Pulse Output		
GPM/Pulse = K factor		
TVF Terminal	Wire Color	Description
7	Shield	-VDC
8	Red	+VDC
10	Blue	Pulse
Jump 13 & 8		

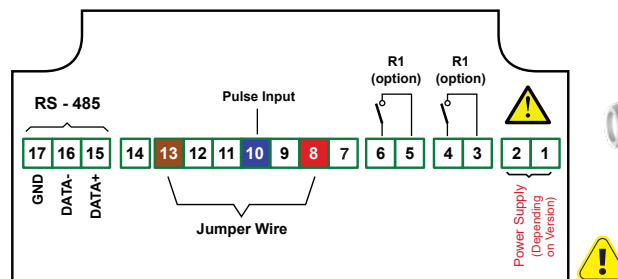



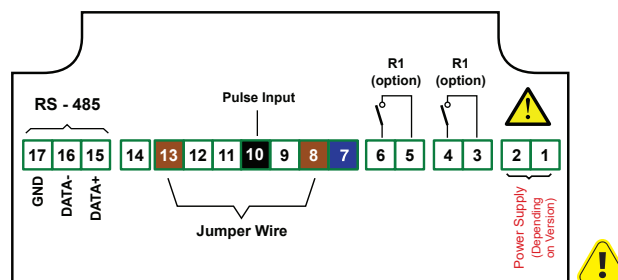



ProPulse®2 – Pulse Output		
TVF Terminal	Wire Color	Description
7	Blue	-VDC
8	Brown	+VDC
10	Black	Pulse
Jump 13 & 8		



Programming K Factor









STEPS	DISPLAY	OPERATION
1 Main Display   		MAIN DISPLAY
2 Relay 1   		RELAY 1 Settings
3 Input  		INPUT Menu
4 K Factor  		Press  or  → Select PULSEL (K Factor)
5 K Factor Value   		Enter K FACTOR Value Press  or  to change digit Press  to advance to next digit Note: Enter the K Factor value according to the Flow Unit. Eg: To display flow in GPM, Enter K Factor corresponding to GPM.
6 Save Value  		Save Selection
7 K Factor  		PULSEL
8 Input  		Input Menu
9 Main Display		Main Display







Programming Relays

STEPS	DISPLAY	OPERATION
1 Main Display   		MAIN DISPLAY
2 Relay 1  		RELAY 1 Settings
3 Source  		SOURCE Menu
4 FL0 bAt tot  		Press  or  → Select FL0 (Flow)
5 Save  		Save Selection
6 Source  		Source
7 Set Point 1  		SET POINT 1
8 Set Point 1 Value   		Enter SET POINT 1 Value Press  or  to change digit Press  to advance to next digit
9 Save  		Save Value
10 Set Point 1  		SET POINT 1

LevelPro® — TVF Series

Flow Display | Controller | Batcher



































STEPS	DISPLAY	OPERATION
11 Set Point 2 		SET POINT 2* * Option available only when the MODE is set to In/Out
12 Set Point 2 Value  		Enter SET POINT 2 Value Press  or  to change digit Press  to advance to next digit
13 Save 		Save Value
14 Set Point 2 		Set Point 2
15 Hysterisis 		HYSTERISIS Menu
16 Hysterisis Value  		Enter HYSTERISIS Value Press  or  to change digit Press  to advance to next digit
17 Save 		Save Value
18 Hysterisis 		Hysterisis Menu
19 Mode 		MODE Menu
20 On Off In Out 		Press  or  → Select On OFF In Out









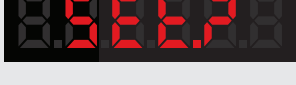



















STEPS	DISPLAY	OPERATION
<p>21 Save ▶</p> 		Save Selection
<p>22 Mode ▶</p> 		Mode Menu
<p>23 Relay 1 ▶</p> 		Relay 1 Menu
<p>24 Main Display ▶</p>		Main Display

Programming Batching

























STEPS	DISPLAY	OPERATION
1 Main Display		MAIN DISPLAY
ESC MENU 3 SEC		
2 Relay 1		RELAY 1 Settings
3 Source		SOURCE Menu
4 FLo bAt tot		Press or → Select bAt (Batch)
5 Save		Save Selection
6 Source		Source Menu
7 Set Point		SET POINT
8 Set Point Value		Enter SET POINT Value
2 SEC		Press or to change digit Press to advance to next digit
9 Save		Save Value
10 Set Point		Set Point
11 Relay 1		Relay 1 Menu
12 Main Display		Main Display
13 Batching Mode		BATCHING MODE
to start batching		
		Note: Switching between Flow rate, Totalizer and Batching can be done by pressing Σ /RESET button. Kind of displayed value is signalled by " Σ " LED. Σ LED ON : Totalizer Σ LED OFF: Flow Rate Σ LED Pulsing: Batching







Programming Output (For 4-20mA Output Models)

STEPS	DISPLAY	OPERATION
1 Main Display   		MAIN DISPLAY
2 Relay 1   X 9		Relay 1 Settings
3 Output  		OUTPUT Menu
4 Output Mode  		OUTPUT MODE
5 4-20mA  		Press  or  → Select 4-20
6 Save  		Save Selection
7 Output Mode  		Select OUTPUT MODE
8 Source  		SOURCE Menu
9 FLo bAt tot  		Press  or  → Select FLo (Flow)
10 Save  		Save Selection

STEPS	DISPLAY	OPERATION
<p>11 Source</p> 		Source Menu
<p>12 4mA</p> 		Setting 4mA (LOW VALUE)
<p>13 4mA Value</p>  		Enter 4mA Value
		Press  or  to change digit Press  to advance to next digit
<p>14 Save</p> 		Save Value
<p>15 4mA</p> 		4mA (Low Value)
<p>16 20mA</p> 		Setting 20mA (HIGH VALUE)
<p>17 20mA Value</p>  		Enter 20mA Value
		Press  or  to change digit Press  to advance to next digit
<p>18 Save</p> 		Save Value
<p>19 20mA</p> 		20mA (High value)
<p>20 Output</p> 		Output Menu
<p>21 Main Display</p>		Main Display







Resetting Batch

STEPS	DISPLAY	OPERATION
1 Main Display   		MAIN DISPLAY
2 Relay 1   X 4		Relay 1 Settings
3 Batch Settings  		BATCH Menu
4 Batch Resolution   X 5		BATCH RESOLUTION
5 Mode Clear  		MODE CLEAR
6 OFF on  		Press  or  → Select on
7 Save  		Save Selection
8 Mode Clear  		Mode Clear
9 Batch Settings  		Batch Menu
10 Main Display  		Main Display

STEPS	DISPLAY	OPERATION
11 Batching Mode 		BATCHING MODE  <p>Note: Switching between Flow rate, Totalizer and Batching can be done by pressing Σ/RESET button. Kind of displayed value is signalled by "Σ" LED.</p> <p>Σ LED ON : Totalizer Σ LED OFF: Flow Rate Σ LED Pulsing: Batching</p>
12 Clear Batch 		Clear Batch
13 Main Display		Main Display

Resetting Totalizer

STEPS	DISPLAY	OPERATION
1 Main Display 		MAIN DISPLAY
2 Relay 1 		Relay 1 Settings
3 Totalizer Menu 		TOTALIZER Menu
4 Totalizer Resolution 		BATCH RESOLUTION
5 Mode Clear 		MODE CLEAR
6 off on 		Press  or  → Select on

STEPS	DISPLAY	OPERATION
7 Save 		Save Selection
8 Mode Clear 		Mode Clear
9 Totalizer Menu 		Totalizer Menu
10 Main Display 		Main Display
11 Totalizer Mode 		TOTALIZER MODE  <p>Note: Switching between Flow rate, Totalizer and Batching can be done by pressing Σ/RESET button. Kind of displayed value is signalised by "Σ" LED.</p> <p>Σ LED ON : Totalizer Σ LED OFF: Flow Rate Σ LED Pulsing: Batching</p>
12 Clear 		Clear Totalizer
13 Main Display		Main Display

Setting Decimal Point

STEPS	DISPLAY	OPERATION
<p>1 Main Display</p> 		MAIN DISPLAY
<p>2 Relay 1</p> 		Relay 1 Settings
<p>3 Flow Menu</p> 		FLOW Menu *
<p>4 Flow Precision</p> 		FLOW PRECISION
<p>5 Decimal Point</p> 		DECIMAL POINT
		Press  or  to change Decimcal Point
<p>6 Save</p> 		Save Selection
<p>7 Flow Precision</p> 		Flow Precision
<p>8 Flow Menu</p> 		Flow Menu
<p>9 Main Display</p>		Main Display

* To change decimal points for Batch | Totalizer, select Batch | Totalizer Menu

Warranty, Returns and Limitations

Warranty

Icon Process Controls Ltd warrants to the original purchaser of its products that such products will be free from defects in material and workmanship under normal use and service in accordance with instructions furnished by **Icon Process Controls Ltd** for a period of one year from the date of sale of such products. **Icon Process Controls Ltd** obligation under this warranty is solely and exclusively limited to the repair or replacement, at Icon Process Controls Ltd option, of the products or components, which **Icon Process Controls Ltd** examination determines to its satisfaction to be defective in material or workmanship within the warranty period. **Icon Process Controls Ltd** must be notified pursuant to the instructions below of any claim under this warranty within thirty (30) days of any claimed lack of conformity of the product. Any product repaired under this warranty will be warranted only for the remainder of the original warranty period. Any product provided as a replacement under this warranty will be warranted for the one year from the date of replacement.

Returns

Products cannot be returned to **Icon Process Controls Ltd** without prior authorization. To return a product that is thought to be defective, go to www.iconprocon.com, and submit a customer return (MRA) request form and follow the instructions therein. All warranty and non-warranty product returns to **Icon Process Controls Ltd** must be shipped prepaid and insured. **Icon Process Controls Ltd** will not be responsible for any products lost or damaged in shipment.

Limitations

This warranty does not apply to products which: 1) are beyond the warranty period or are products for which the original purchaser does not follow the warranty procedures outlined above; 2) have been subjected to electrical, mechanical or chemical damage due to improper, accidental or negligent use; 3) have been modified or altered; 4) anyone other than service personnel authorized by **Icon Process Controls Ltd** have attempted to repair; 5) have been involved in accidents or natural disasters; or 6) are damaged during return shipment to **Icon Process Controls Ltd** reserves the right to unilaterally waive this warranty and dispose of any product returned to **Icon Process Controls Ltd** where: 1) there is evidence of a potentially hazardous material present with the product; or 2) the product has remained unclaimed at **Icon Process Controls Ltd** for more than 30 days after **Icon Process Controls Ltd** has dutifully requested disposition. This warranty contains the sole express warranty made by **Icon Process Controls Ltd** in connection with its products. **ALL IMPLIED WARRANTIES, INCLUDING WITHOUT LIMITATION, THE WARRANTIES OF MERCHANTABILITY AND FITNESS FOR A PARTICULAR PURPOSE, ARE EXPRESSLY DISCLAIMED.** The remedies of repair or replacement as stated above are the exclusive remedies for the breach of this warranty. **IN NO EVENT SHALL Icon Process Controls Ltd BE LIABLE FOR ANY INCIDENTAL OR CONSEQUENTIAL DAMAGES OF ANY KIND INCLUDING PERSONAL OR REAL PROPERTY OR FOR INJURY TO ANY PERSON. THIS WARRANTY CONSTITUTES THE FINAL, COMPLETE AND EXCLUSIVE STATEMENT OF WARRANTY TERMS AND NO PERSON IS AUTHORIZED TO MAKE ANY OTHER WARRANTIES OR REPRESENTATIONS ON BEHALF OF Icon Process Controls Ltd.** This warranty will be interpreted pursuant to the laws of the province of Ontario, Canada.

If any portion of this warranty is held to be invalid or unenforceable for any reason, such finding will not invalidate any other provision of this warranty.

For additional product documentation and technical support visit:

www.iconprocon.com | e-mail: sales@iconprocon.com or support@iconprocon.com | Ph: 905.469.9283